

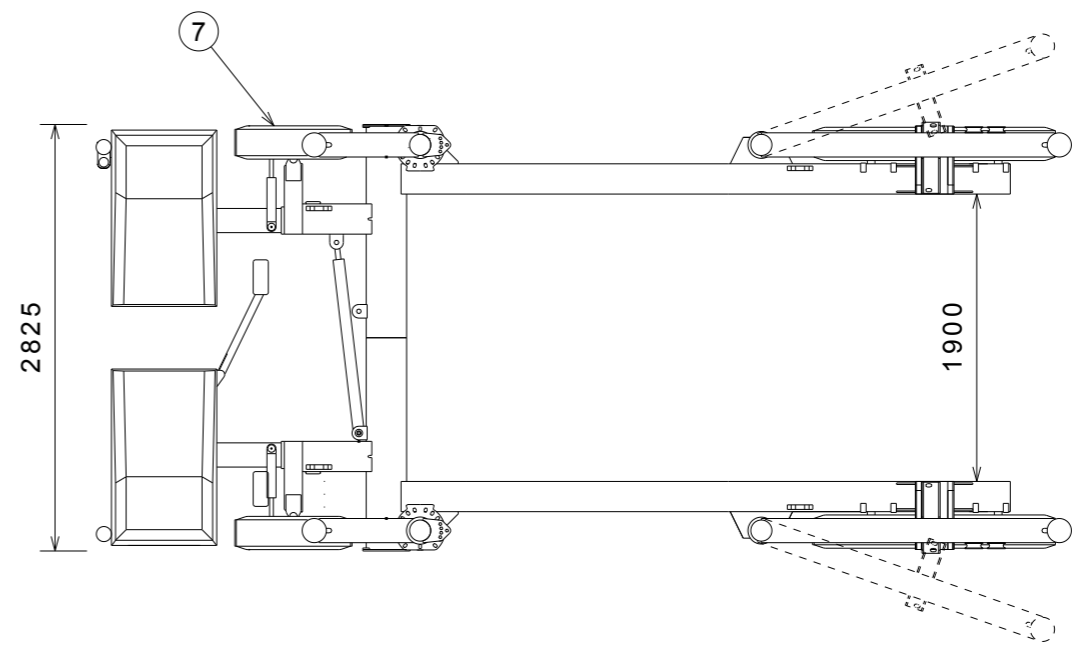

- Note**
1. Dimensions with standard crossbeam 2,8m
  2. Ground clearance given unladen
  3. Minimum transport width 2,8m with standard crossbeam
  4. All dimensions has been rounded off
  5. Drawings are subject to change without prior notice
  6. Normal configuration
  7. Narrow configuration

Data	
Service Weight:	4,000 kg
Max load:	12,000 kg
Max load/sling front:	4,800 kg
Max load/sling rear:	7,200 kg
Highest slope:	1/8
Max side slope:	1/15
Engine:	Kubota 26 kW
Maximum speed:	8 km/h

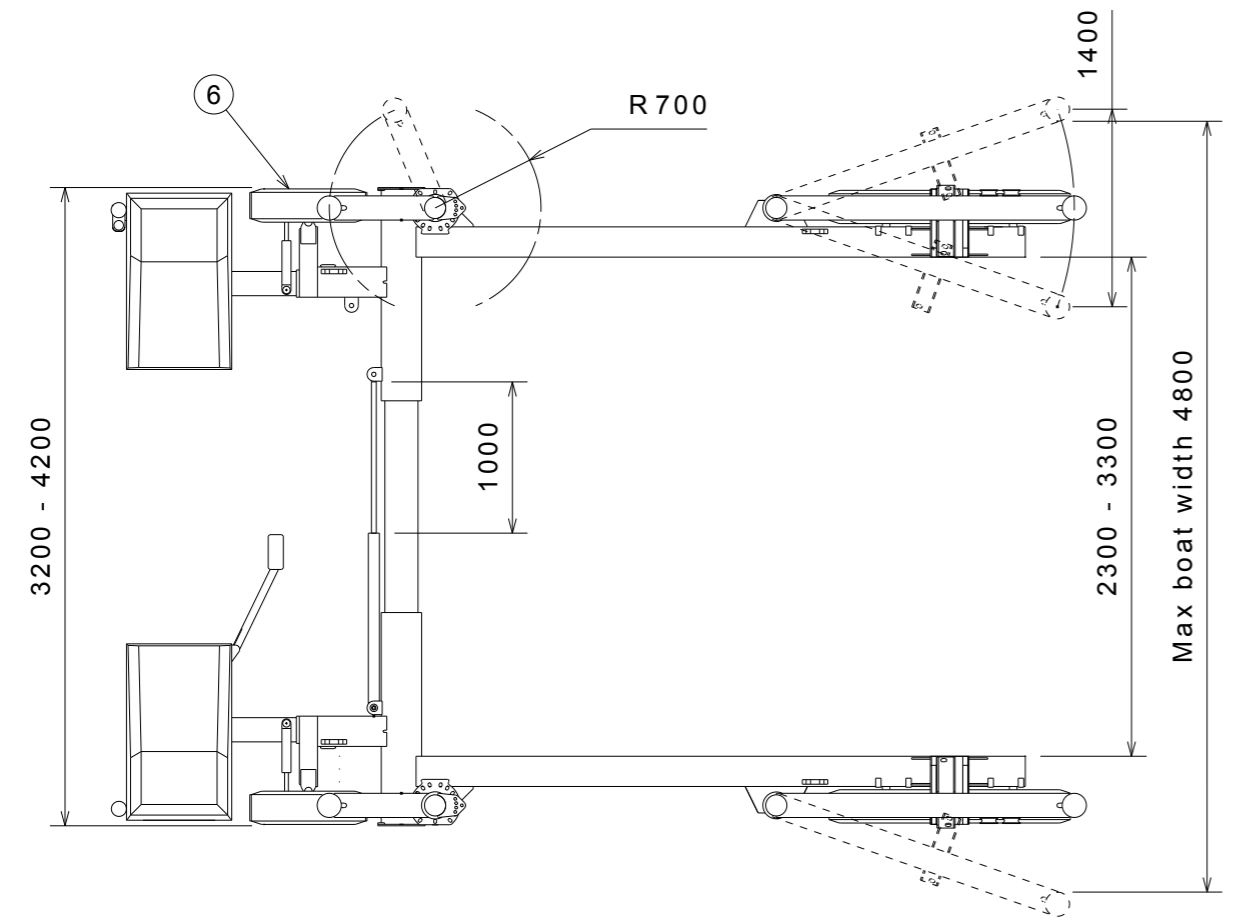

Det.nr	Ant.	Benämning			Material	Mod.nr ämne Dimension	Anm.	
Konstr. <b>IG</b>	Ritad <b>ML</b>	Kop.	Kontr.	Stand.	Godk.	Skala <b>1:50</b>	Ersätter <b>2016-03-22</b>	Ersatt av
 Djupvik SE-471 98 Fagerfjäll Sweden						<b>Sublift 12t</b>		Dat. <b>2016-04-15</b>
								Ritn.nr <b>GA 12 TON</b>